

FRONT ISOMETRIC VIEW
SCALE .375 : 1

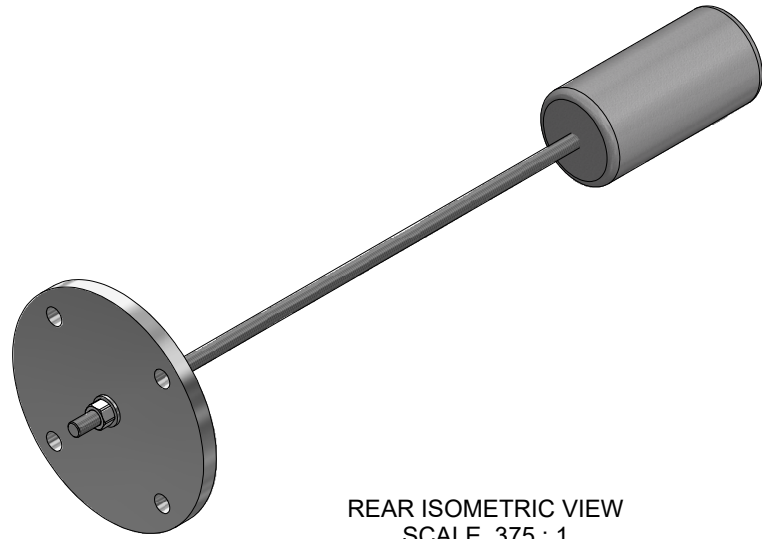

REAR ISOMETRIC VIEW
SCALE .375 : 1

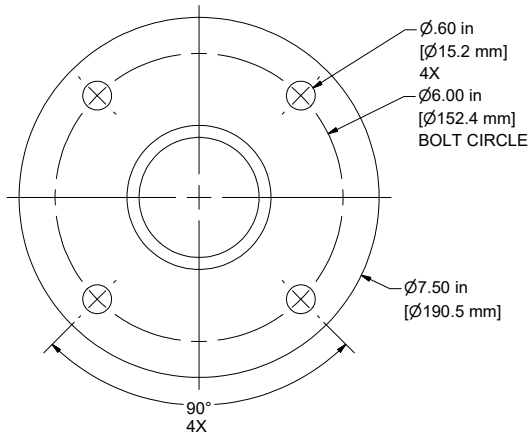

FRONT VIEW
SCALE .50 : 1

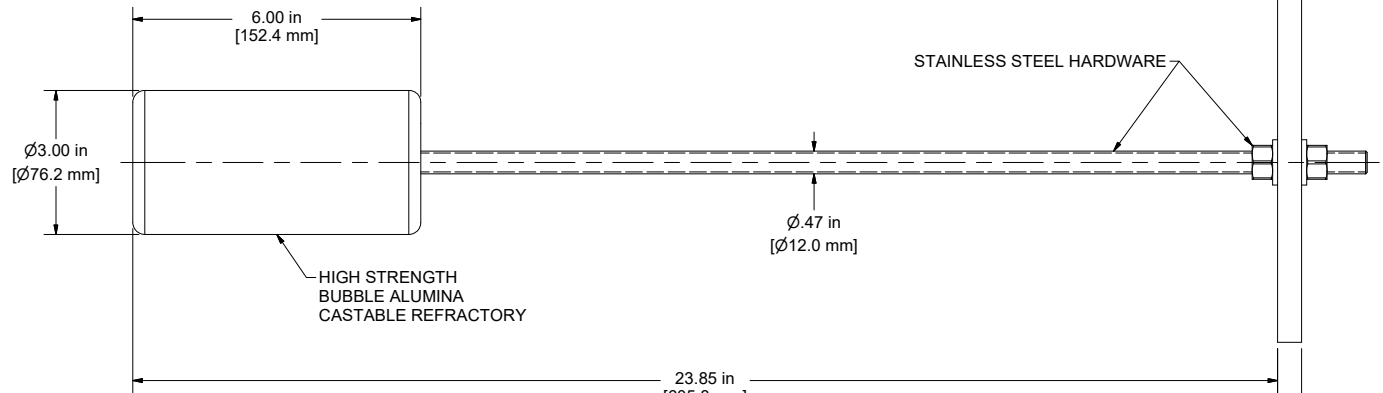

RIGHT SIDE VIEW
SCALE .50 : 1

NOTES:

- 24" SYSTEM REFRACTORY PLUG ASSEMBLY FINISHED P/N: VC10507-430.
- MATERIALS OF CONSTRUCTION AS NOTED.
- PROVIDED MOUNTING HARDWARE INCLUDES: CARBON STEEL; (4) M12 x 1.75 x 70mm OR LONGER HEX BOLTS, (4) M12 x 1.75 HEX NUTS & (8) M12 WASHERS.
- IMPORTANT! THE TIP OF THE CAST REFRACTORY CYLINDER SHOULD END UP FLUSH WITH THE INNER WALL OF THE FURNACE. SEE THE H.T. CAMERA INSTALLATION, OPERATION & MAINTENANCE MANUAL P/N: TA6205-1.

NOTICE
THIS DRAWING IS THE PROPERTY OF J.M. CANTY AND MUST BE RETURNED WITHOUT REPRODUCTION OR DUPLICATION, AT ANY TIMES UPON REQUEST, BUT IN ANY EVENT AS SOON AS IT HAS SERVED THE PURPOSE FOR WHICH IT WAS FURNISHED. WHILE IN THE POSSESSION OF THE RECIPIENT, IT MUST BE PROPERLY SAFEGUARDED AGAINST DISCLOSURE TO ANYONE EXCEPT THOSE EMPLOYEES WHO REQUIRE IT FOR WORK OR JOB. THE RECIPIENT MUST KEEP CONFIDENTIAL AND REQUIRE HIS (HER) EMPLOYEES TO KEEP CONFIDENTIAL THE INFORMATION CONTAINED HERE ON.

IMPORTANT
UNLESS NOTED THE PRIMARY DIMENSIONS ARE IN INCHES AND THE SECONDARY UNITS ARE IN MILLIMETERS.

DRAWN BY MFR	DATE 17-Jul-24
APPROVAL MFR	DATE 17-Jul-24
ENGINEERING ANALYSIS CURRENT	DATE
MFG. APPROVAL PENDING	DATE
QUALITY CONTROL VJS	DATE

J.M. CANTY INC.
6100 DONNER RD.
BUFFALO, N.Y. 14094
U.S.A.

CANTY
WWW.JMCANTY.COM

J.M. CANTY INTL. LTD.
BALLYCOOLIN BUS. PK.
BLANCHARDSTOWN
DUBLIN 15, IRELAND

TITLE
SALES DRAWING / WALL MOUNT TUBE PLUG ASSEMBLY, 24", S.S., P/N VC10507-430

REVISION
0

FILE NAME
TA11950-1145

SCALE AS NOTED SIZE C SHEET 1 OF 1